

NimRock.com STAGE ORDER | BÜHNENANWEISUNG | EUROPEAN TOUR 2009

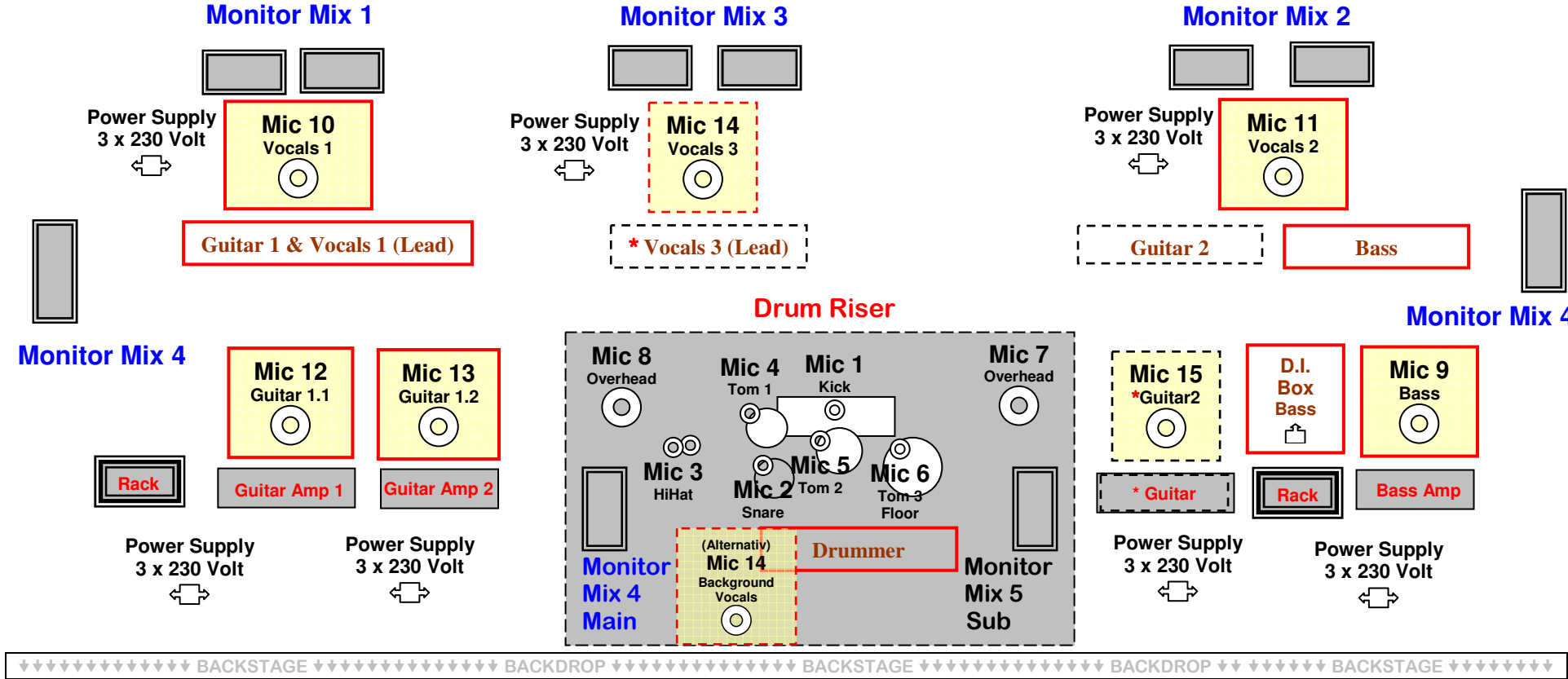

STAGE MEASUREMENTS MINIMUM | BÜHNENGRÖSSE MINIMUM :: 6 x 4 Meter | DRUM RISER MINIMUM :: 2 x 2 Meter
MONITORING | IN-EAR MONITORING :: SOME BAND MEMBERS WILL USE IN-EAR MONITORING IN THE NEAR FUTURE

THE LOCAL PROMOTER / ORGANIZER IS RESPONSIBLE AT HIS SOLE COST FOR LOCAL PROMOTION, PREPARATION, ARRANGEMENTS, TRANSACTIONS, THE ACCOMPLISHMENT OF THIS CONCERT AND THE OVERALL SUCCESS OF THIS EVENT; THIS INCLUDES ALL FORMS OF PERMITS, LICENSES, CERTIFICATES, TAXES, DUTYS, INSURANCES AND LIABILITY AS RELATED TO THIS CONCERT. CONTACT US IMMEDIATELY IN CASE YOU HAVE ANY PROBLEMS OR QUESTIONS. OTHERWISE WE CONCLUDE, THAT YOU CAN COMPLY WITH ALL POINTS AS PRESENTED. ORGANIZER IS RESPONSIBLE FOR SAFETY, LIFE, HEALTH AND EQUIPMENT OF ALL PERSONS INVOLVED; THIS INCLUDES (BUT IS NOT LIMITED TO) ARTISTS, AUDIENCE, MEMBERS OF THE STAFF, AGENTS, VOLUNTEERS AND SO ON. PROMOTER WILL ALWAYS OBSERVE THE LAWS AND COMPLY WITH REGULATIONS AS GIVEN BY THE LOCAL AUTHORITIES OR GOVERNMENT. THIS CONCERT AGREEMENT IS BASED ON THE ARTISTS STANDARD CONTRACT. THIS STANDARD CONTRACT CAN ALWAYS BE INSPECTED, READ AND PRINTED FROM ARTISTS (OR AGENTS) WEBSITE. THIS AGREEMENT IS LEGALLY BINDING; NO MATTER IF PROMOTER HAS SIGNED IT OR NOT. CHANGES ARE ACCEPTED AND LEGALLY BINDING ONLY IN WRITING AND SIGNED BY ARTISTS AGENT.

Der lokale Veranstalter/Organisator ist uneingeschränkt verantwortlich für die ordnungsgemäße und erfolgreiche Vorbereitung und Durchführung der Konzertveranstaltung. Der Veranstalter verpflichtet sich alle gesetzlichen Regelungen und Bestimmungen einzuhalten und die Sicherheit aller beteiligten Personen (Mitarbeiter, Musiker, Publikum) und der Technik zu gewährleisten. Es gelten die üblichen Vertragsbedingungen für Konzerte des Künstlers - unabhängig davon ob der Veranstalter diese Bedingungen schriftlich bestätigt hat oder nicht. Die Vertragsbedingungen können jederzeit auf der Offiziellen Website des Künstlers oder dessen Agenten eingesehen, gelesen und ausgedruckt werden. Änderungen oder Abweichungen sind nur gültig durch die schriftliche Bestätigung des Künstlers/Agenten.

Bitte nächste Seite beachten! Please refer to the next Page! ► **INPUT LIST | MICROPHONES | EFFECTS | PROCESSING | FOH MIX | MONITOR MIX | BACKLINE | P.A. | STAGE**

Info & Contact | Management & Bookings | Email: BookingNimRock@MEGA-mgt.com | Phone / Mobiltelefon (+49) (0)178-8884628 | EMAIL: Marcus-Lindner@MEGA-Mgt.com

INPUT LIST | MICROPHONES | EFFECTS | PROCESSING | FOH MIX | MONITOR MIX | BACKLINE NimRock.com

Ch.	Position	1st Choice / 1. Wahl - Microphone	2nd Choice / Alternative	Proc.	Effects ***	Monitor	X
1	Bass Drum / Kick	AKG D 112 - Shure Beta52	AudioTechn. Pro25/ATM250 - Audix D6/F14	Gate/Comp		Mix # 4	
2	Snare	Shure SM 57	Shure SM 57	Comp.	**		
3	HiHat	Oktava MK012 - Audix F15	AKG C451 - Shure PG81 - Sennh.E614				
4	Tom 1	Sennh.MD421 - Shure SM57	Shure Beta57/Beta56/PG56	Gate			
5	Tom 2	Sennh.MD421 - Shure SM57	Shure Beta57/Beta56/PG56	Gate			
6	Tom 3	Sennh.MD421 - Shure SM57	Shure Beta57/Beta56/PG56	Gate			
7	Overhead left / links	Rode NT5 - Oktava MK012	AKG C1000 - Shure PG81 - Sennh.E614				
8	Overhead right / rechts	Rode NT5 - Oktava MK012	AKG C1000 - Shure PG81 - Sennh.E614				
9	Bassguitar	Audix D6/F14/D4	Shure SM57 - EV RE20 - Shure Beta52	(Comp.)			
10	Vocals 1 Lead	Headset	Shure Super55/SH55 - Sennh.E835	Comp.	Vocalist ♪		
11	Vocals 2 Background	Shure SM58 - Sennh.E835	Shure SM57/Beta58 - BehringerXM8500	Comp.	Reverb/Delay **		
12	Guitar 1 (Amp1)	Shure SM57	Shure Beta57/PG57 - Audix D6	Comp.	Stereo-Chorus **		
13	Guitar 1 (Amp2)	Sennheiser MD421 - Sennh.E606	EV Co4 - Shure SM57	Comp.	Stereo-Chorus **		
14	Vocals 3 Lead * or Drums BGV	Shure SM58 -	Shure Beta58/PG58	Comp.	Vocalist ♪		
15 *	Guitar 2 *	Shure SM57	Shure SM57/PG57/Beta57	Comp.	Stereo-Chorus (Solo) **		
16	D.I.Box Bassguitar	combined/mixed with Sansamp		(Comp.)			
(17)	Snare Bottom / Unten	Shure SM 57	Shure Beta57/PG56				
(18)							
*	Vocalist 3 Lead & Guitar 2	will not appear at all performances	treten nicht auf allen Konzerten mit auf				
♪ VOCALIST EFFECTS ▶		1st Choice: T.C. Electronics ▶ 2nd Choice: DigiTech Vocalist ▶	Voice Works Plus, VoiceLive, (VoiceDoubler) Vocalist Live Pro, Vocalist 4 Live				
** MICs PROCESSING FX ▶		Please refer to the input list, please use the best possible mics available.	Reverb, Delay, Effects: Lexicon MX400(300) or TC Electronic M-ONE (D-TWO) or YamahaSPX Compressor/Gates: dbx 166(266) or TC ElectronicC300(C400) or Alesis3630 or BehringerMDX SnareDrum ▶Plate / Gated Reverb ▶ Lexicon/TC Electronic/Alesis				
MONITOR MIXES (4 minimum) ▶		#1 Vocals/Guitar: Everything; focus own voice and own guitar #2 Guitar/Bass: All vocals, bass, guitar	#3 Vocals 3 / Lead: All guitars, bass, all vocals, drums #4 Main Monitor Mix: All instruments & vocals #5 Main Mix plus Subbass/BassShaker or similar				
*** EFFECTS & SETTINGS ▶		Please refer to specifications! ▶ Unbedingt Anweisungen befolgen! ▶	Prior to Soundcheck we will provide detailed description (Processing, Effect Settings, Delay Time, Eq., etc.). Zum Soundcheck werden wir die detaillierten Informationen zur Einstellung der Effekte (Delay Zeit, etc.) übergeben.				
BACKLINE ▶		Please provide the following Equipment (if not otherwise indicated). ▶ Bitte stellt folgendes Equipment zur Verfügung (wenn nicht anders angegeben). ▶	DRUMS: 22" BassDrum, 14" Snare, 2 Toms, 1 FloorTom, HiHat & Snare Stands, 3 Cymbal Stands, Throne, :: Sonor 3000/2000/S-Class -or- similar (NO entry level drumkits. Pro Hardware ONLY. KEINE Anfänger Drumkits! NUR stabile professionelle Stative / Hardware.) Drummer will bring KickPedal & Cymbals (bringt der Schlagzeuger selber mit) BASS AMP & 15" CAB or 15" COMBO: Ampeg SVT -or- Peavey VB/TNT/TKO -or- Trace Elliot GUITAR AMPS: Amp1: Peavey Ultra -or- Peavey 5150/6505 (or Laney Tony Iommi Sign.Model) Amp2: Peavey Classic 30 -or- Laney Lionheart L20H -or- VOX AC30HH GUITAR CABS: Two (2) zwei Cabs/Boxen 2x12"Hatari -or- 1x12"Hatari -or- Laney LT212 SPEAKER: Guitar Boxen/Cabs must be equipped with Celestion G12H30 ONLY!!! GUITAR FX: Two (2) zwei HUSH Noise Reduction (Pedal)				
VOCALS ▶		MUST INCLUDE THE FOLLOWING ▶ UNBEDINGT BEREITSTELLEN ▶	Compressor (Gate) - Voice Doubling/Harmonizer - Reverb - Delay Bei Ansagen zwischen den Songs MÜSSEN ALLE Hall/Harmonizer/Doubler Effekte AUS sein! In between the songs (announcements) ALL FX (excl. Compressor) MUST BE SHUT OFF!				
TECHNICAL SUPPORT ▶		TECHNISCHE FRAGEN ▶	EMAIL: NimRockGuitarTech@HatariMusic.com				

* SOME SHOWS AS 3 PIECE LINE-UP ONLY | EINIGE SHOWS NUR MIT 3 MUSIKERN :: Guitar 1 & Vocals 1 | Bass Player & Vocals 2 | One(1) x Drummer & BackgroundVocals